

A stylized white graphic element resembling a wing or a stylized letter 'P' is positioned above the brand name.

PROMASTER[®]

Macrolume TTL

OPERATING INSTRUCTIONS

ELECTRONIC FLASH

Parts Identification

Dual Macro Flash Head (Front view)

- 1) Flashtube Housing
- 2) Flashtube Power Cord
- 3) Upper Auto Focus Assist Illumination Lamp
- 4) Right Light Reducing Control Wheel
- 5) Right Flashtube Reflector
- 6) Right Adapter Mounting Ring Button
- 7) 1/4-20 Tripod Mounting Thread
- 8) Lower Auto Focus Assist Illumination Lamp
- 9) Left Light Reducing Control Wheel
- 10) Left Flashtube Reflector
- 11) Left Adapter Mounting Ring Button

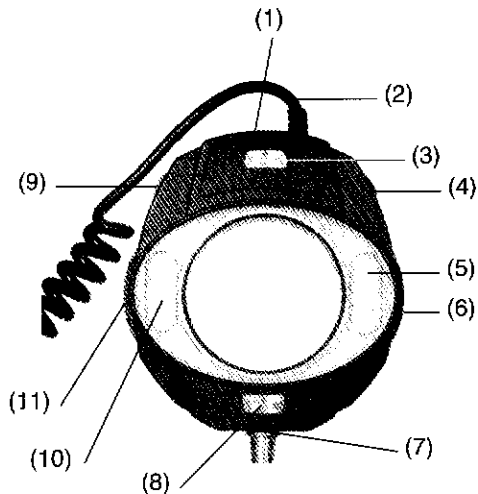

Dual Macro Flash Head (Back View)

- 1) Left Light Reducing Control Wheel
- 2) Left Light Reducing Position Window
- 3) Left Adapter Mounting Ring Button
- 4) Flashtube Selector Switch
- 5) Right Light Reducing Control Wheel
- 6) Right Light Reducing Position Window
- 7) Right Adapter Mounting Ring Button

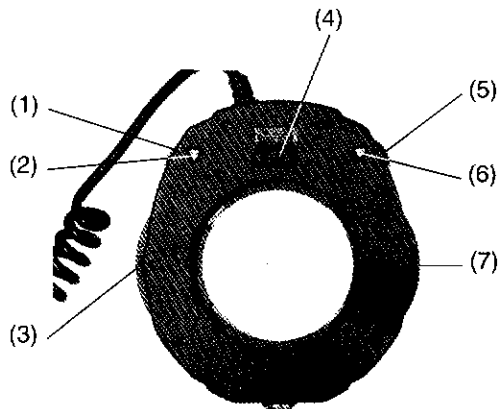

Power Supply (Front View)

- 1) Macro Flash Head Mounting Interface
- 2) Battery Compartment Cover
- 3) TTL Dedicated Camera Adapter
- 4) Auto Focus Infrared Beam

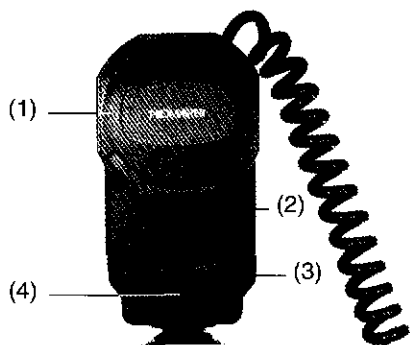

Power Supply (Back View)

- 1) Flash Ready Indicator Light
- 2) Auto Check Indicator Light
- 3) Power Switch On/OFF
- 4) Flash Exposure Mode Selector
- 5) Auto Focus Assist Illumination Lamp Button
- 6) Pulsed Modeling Lamp Button
- 7) Test (open flash) Button
- 8) FTD5000 TTL Dedicated Camera Adapter

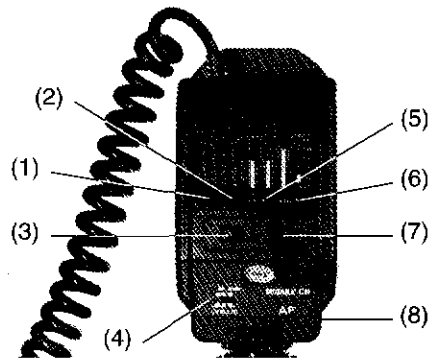

Battery Operation

1. Open the battery compartment cover by sliding the door in the direction of the arrow.
2. Insert four 1.5volt penlight batteries following the (+) (-) sign as indicated inside the battery compartment.
3. Replace the battery compartment door by sliding the door back into the grooves and lock in place.

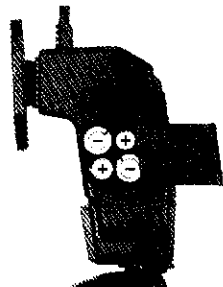

IMPORTANT:

- The batteries should be inserted in the correct position.
- For best results, use Alkaline Batteries.
- Use fresh batteries regularly.

Key Features

1) Selectable Flash Mode

Choose from three different flash exposure modes, Manual, Automatic and TTL mode with the proper FTD5000 dedicated module.

2) Fully Dedicated

The Promaster Macrolume will automatically set the correct flash synchronization and proper aperture. LED indicators inside the camera's viewfinder displays X-Sync and confirms flash ready status. TTL flash exposure is confirmed as a blinking LED.

3) Built-in Power Ratio Setting

In Manual mode, provides exposure control for close-up, action freezing, rapid sequence photography and fill-in flash. Settings are Full and 1/16th power output.

4) FTD 5000 Series Module Dedication

With the Promaster's convenient interchangeable module system many dedicated camera systems can be interfaced with the Macrolume TTL Flash.

5) Built-in Pulsed Modeling Lamp

Provides high intensity illumination for setting lighting ratio between the Dual Flashtubes. Also helpful in critical focusing.

6) Built-in Auto Focus Assist Illumination Lamp

Assist the camera's Auto Focus system by providing additional continuous illumination. Also helpful in manual focus cameras.

7) Dual Mounting Options

The Macro Flash housing can be mounted independently via its 1/4-20 tripod mounting thread or attached to the power supply interface adapter.

8) Tilting Interface Adapter

Provides positioning of the entire Macro Flash housing in a tilting UP/DOWN movement.

9) Dual Flash Tube Selector Switch

Both Left and Right Flash Tubes can fire simultaneously or individually by setting the Flash Tube Selector Switch.

10) Dual Light Reducing Filters

Built-in adjustable Light Reducing Filter provides added exposure and light balancing control.

Mounting the Macrolume Flash Head on the Power Supply control housing.

1. The Macrolume Flash head can be attached to the power supply control housing for close-up photography. The Macrolume Flash head can tilt UP/DOWN once it is attached to the interface adapter. (see photo)
2. The position of the flash reflector tubes can be set for vertical or horizontal positioning to match the required lighting for the subject. (see photo)
3. To attach the Macrolume Flash housing to the power supply control housing, press the adapter ring mounting buttons on both sides of the Macrolume Flash housing and insert over the interface adapter. (see photo)



Mounting the Macrolume Flash Head on your camera lens for Macro Photography

To Mount the Macrolume Flash Head

1. Match the correct adapter ring outside diameter of your camera lens and fasten securely. (Ring adapters 49mm or 52mm included)
2. Attach the Macrolume Flash head to the adapter ring by pressing the adapter ring mounting buttons on both sides of the Macrolume Flash housing and insert over the ring adapter. (see photo)
3. The position of the flash reflector tubes can be set for vertical or horizontal positioning to match the required lighting for the subject. (see photo)



NOTE: A Cokin Adapter "A" is included for attaching the Cokin "P" Ring to the Macrolume Flash housing and camera lens. (see Photo)

For special color filters and Cokin special effects filters, use the included Adapter "B" for attaching Cokin "P" Filter-Holder to the Macrolume Flash housing and camera lens.



52 mm Ring Adapter



49 mm Ring Adapter



Adapter "A"



Adapter "B"

Macrolume Flash Dedication

This flash unit requires Interchangeable Dedicated Module to fit the following dedicated mating cameras for dedicated flash operation. Please see Module Instructions for details of operation of this flash unit.

AF MODULES:-

- AF MODULE CN is for CANON
- AF MODULE ML is for MINOLTA
- AF MODULE MLi is for MINOLTA"i"
- AF MODULE NK is for NIKON
- AF MODULE YS is for YASHICA
- AF MODULE PX is for PENTAX

EOS 650, 620, 750, 850, 630, 10, REBEL, ELAN, etc
MAXXUM 7000, 9000, 5000
MAXXUM 7000i, 3000i, 5000i, 8000i, 7xi, 3xi, etc
N2020, N4004, N8008, N6006, etc
230AF, 200AF, etc
SFi/SFX, SF1N, SF10/SF7, etc

NON-AF MODULES:-

- MODULE CN is for CANON
- MODULE ML is for MINOLTA
- MODULE PX is for PENTAX

- MODULE NK is for NIKON
- MODULE RC is for RICOH
- MODULE YS is for YASHICA
- MODULE OM is for OLYMPUS
- MODULE ST is for STANDARD

A-1, AE-1, AE-1 Program, New F-1, AV-1, AL-1, AT-1, T50, T70
XD Series, XG Series, X700, X570, X370
ME-Super, ME-F, MV, MG, LX, Super A Program, Program Plus,
A3000, P3N
FE, EM, FE2, FA, FG, FM2, FG20, N2000
XR-Series, KR-Series, XR-P, XR-M/XR-X
FX-Series
OM1, OM2, OM2N, OM10, OM4, OMF, OMG, OM2S, OM-PC,
SLR cameras

● As different models of cameras operate differently for flash photography, you should read the Instructions Manual of your camera for details of flash operation.

● Before attaching the Module onto the Flash Unit, always make sure that the Module and the Flash Unit contact points are all clean. The stain or dirt on surface of the contact points on the Module side or on the Flash Unit side may cause malfunction. You may use soft cloth to clean the contact points on both sides.

Attaching and Detaching the Dedicated Module

1. To attach the module, position the right-side fixed attachment hook onto the flash unit and then push the left-side of the module upward until the left-side movable attachment hook clicks into position.

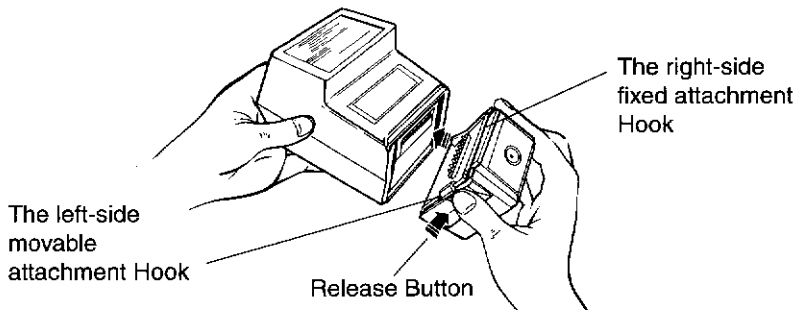

2. To detach the module, press the release button on the left-side of the module and while pressing the button, detach the module.

IMPORTANT NOTES:

- WHEN ATTACHING THE MODULE ONTO THE FLASH UNIT OR DETACHING THE MODULE FROM THE FLASH UNIT, ALWAYS MAKE SURE THAT THE POWER OF THE FLASH UNIT HAS BEEN SWITCHED OFF.
- DO NOT ATTACH THE FLASH UNIT TO THE MODULE WHILE THE MODULE IS MOUNTED ON THE CAMERA.
- WHEN MOUNTING THE FLASH UNIT WHICH HAS BEEN ATTACHED TO THE MODULE ONTO THE CAMERA, ALWAYS MAKE SURE THAT THE POWER OF THE FLASH UNIT HAS BEEN SWITCHED OFF.
- USE THE DEDICATED MODULE ONLY WITH THE DESIGNATED MATING CAMERA. USING IT WITH NON-MATING DEDICATED CAMERA MAY CAUSE DAMAGE TO THE CAMERA, THE FLASH UNIT, THE MODULE OR ALL.

It is important to follow the above instructions. Otherwise, it may cause damage to the flash unit, the module, the camera or all.

Auto Focus Assist Illumination Lamp

When the light is too dim for normal autofocus operation, the autofocus assist illumination lamp can be used to illuminate the dark subjects.

1. Press the autofocus assist illumination lamp button to turn the lamp on
 2. Press the autofocus assist illumination lamp button again to turn the lamp off.
- The autofocus assist illumination lamp turns off automatically after approx. 1 minute or if the flash is fired.
 - In order not to affect the camera's exposure, it is advisable to turn off the illuminator lamp before shooting.

Pulsed Modeling Flash

This feature helps you to view the effects of the flash illumination and see how the shadows will look in relation to your subject before actually taking the picture. When the flash is ready, the modeling illuminator lights up while the modeling lamp button is pressed.

Light Reducing Filter

The built-in adjustable Light Reducing Filter provides added exposure and light balancing control. The brightness of the flashtube illumination can be reduced to approx. 1/4 of the flash output by using the Light Reducing Filter to cover the flashtube reflector.

Auto Check Lamp

On TTL Auto flash mode or Normal Auto flash mode, if exposure was sufficient, the auto check lamp on the flash unit glows at the same moment when the shutter button of the camera is pressed. On Normal Auto flash mode, before actually taking the photos, you can check whether the shooting distance is within the automatic range by pressing test flash button on the flash unit.

Auto Power-Off

A battery-saving automatic power-off circuitry is incorporated in this flash unit. The battery power of the flash unit will be automatically turned off within approximately 5 minutes and the ready indicator LED lamp extinguishes itself. With AF module on some dedicated mating cameras, the flash can be re-activated for firing by touching the shutter-release button of the camera. With other modules, the flash can be re-activated for firing by pressing once the Reset flash button on the flash unit or by switching the flash unit OFF and then ON again.

Determining a Proper Flash Shooting Distance Range

Using the "Aperture/reproduction ratio panel" (with the lens in normal position)

Use the "Aperture/reproduction ratio panel" on the back of the Promaster Macrolume Power Supply Controller to determine the usable aperture at the desired reproduction ratio. The proper aperture depends on the *ISO film speed*, *lens focal length* and the *desired reproduction ratio*.

NOTE: The figures on the panel are effective f-stops. They are not apertures on the lens.

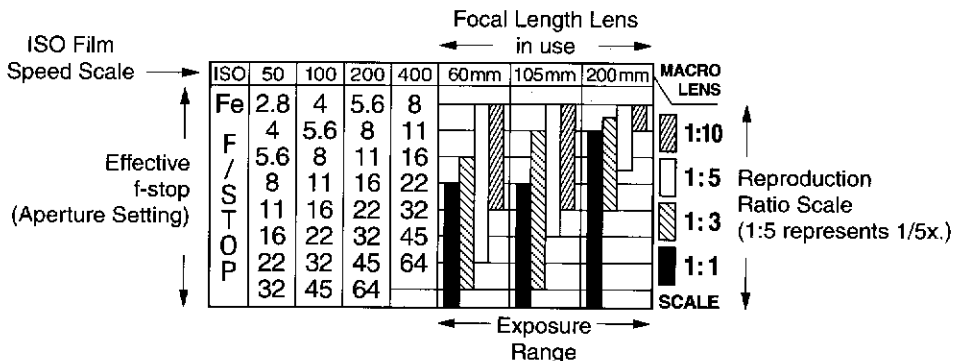

- The settings and scales on the Aperture/reproduction ratio panel are for use with Auto Focus Micro 60mm f/2.8, 105mm f/2.8 and 200mm f/4 lenses.

NOTE: If you are using an AF Zoom Micro lens determine the appropriate figures on the panel depending on the focal length set on the lens. Apply this to other lenses.

- For example, at a 1:5 reproduction ratio with ISO 100 film and the AF Micro 60mm lens, the usable apertures are from f/4 to f/32.

Over or Underexposure results

When using TTL for extreme close-up or macro photography it is possible for the cameras metering system to fail in responding fast enough. In the event that TTL exposures are over or underexposed, use the following coefficient to solve the problem.
 $F/\text{stop (maximum aperture}^*) = \text{Coefficient} / \text{flash-to-subject distance (m/ft)}$

| | | | |
|----------------|--------------|-------------|---------------|
| ISO Film Speed | 100 or below | 125-400 | 500 or more |
| Coefficient | 2/6.6 (m/ft) | 4/13 (m/ft) | 5.6/18 (m/ft) |

* The aperture where overexposed pictures may result in TTL or Auto flash operation if a larger aperture (smaller f/stop) than that is used.

- For Example, when shooting a subject at a distance of 0.25m (0.82ft) using ISO 100 film, the correct aperture is:
 $f/\text{stop} = 2 \text{ (Coefficient)} / 0.25 \text{ (m) (flash-to-subject distance)} = 8$
 $f/\text{stop} = 6.6 \text{ (Coefficient)} / 0.82 \text{ (ft) (flash-to-subject distanced)} = \text{approx. } 8$

TTL Auto Flash Range

The Marcolume TTL provides automatic Through-the-lens (TTL) control of the flash exposure when the proper dedicated camera modules are used with the TTL Auto Flash Metering feature of the camera. This auto mode permits the use of any lens aperture within the flash unit's operating range to enable greater control of depth of field. The larger the aperture (smaller f-number ex- f-2.8) selected, the greater the maximum shooting distance (less depth of field, shorter recycle time). The smaller the aperture (bigger f-number ex-f-16) selected, the lesser the flash shooting distance (more depth of field, longer recycle time).

The TTL Automatic Mode of this flash unit balances the exposure between the main subject illuminated by flash and the background in ambient light, whenever possible. Thus, this TTL mode can be used under conditions ranging from total darkness to fill-in flash scenarios.

Three Factors to consider when choosing an aperture:

- Maximum Flash shooting distance
- Depth of Field
- Flash Recycling time

TTL AUTO FLASH RANGE: (APPROX.)

| ASA Film In Use | | | | Maximum Shooting Distance (ft) | |
|-----------------|-----|-----|------|--------------------------------|------------------|
| 100 | 200 | 400 | 1000 | Dual Flashtube | Single Flashtube |
| 1.4 | 2 | 2.8 | 4 | 25.7 | 28.6 |
| 2 | 2.8 | 4 | 5.6 | 18.0 | 20.0 |
| 2.8 | 4 | 5.6 | 8 | 12.9 | 14.3 |
| 4 | 5.6 | 8 | 11 | 9.0 | 10.0 |
| 5.6 | 8 | 11 | 16 | 6.4 | 7.1 |
| 8 | 11 | 16 | 22 | 4.5 | 5.0 |
| 11 | 16 | 22 | | 3.3 | 3.6 |
| 16 | 22 | | | 2.3 | 2.5 |
| 22 | | | | 1.6 | 1.8 |

Lower Power Manual Flash

In Manual Flash operation, the flash can be set to 1/16th power output position. In this position faster recycling time and more number of flash exposures is possible. It is useful for close-up macro photography and while shooting with a motor-driven camera (up to 2 frames per second). Guide number at this lower power setting is 1/4 of the full guide number (see Guide Number Table).

AF Illuminator For Auto Focusing

When the camera's operating button is pressed halfway, the AF illuminator is automatically activated when required, with low-contrast subjects in low light. This illumination enables the camera's autofocus system to determine focus status and adjust the lens.

The AF Illuminator enables autofocusing with subjects up to about 16 feet away. This distance is for autofocusing only, when focusing manually, flash photograph is possible up to about 28 feet, when using ASA 100 and F 1.4 aperture (please refer TTL Auto Flash range table).

NOTE: The working range for the AF illuminator is based on standard test method with a 50 mm lens. If longer focal lengths are used, the camera may not focus lens accurately. In this case or whenever focus signals blink, set focus mode of the camera switch to M and focus lens manually.

Specifications :

| | |
|--|---|
| Power Source : | 4 (1.5Volt) "AA" Alkaline Batteries or Rechargeable Batteries |
| Recycling Time : | Automatic 0.3 to 10 sec Manual 6 to 10 sec |
| Battery Life : | Approx. 100 to 700 flashes (Depends on the type of batteries and flash distances) |
| Flash Duration (Approx.) : | 1/1400 sec at full power manual mode with dual tubes 1/1250 sec at full power manual mode with single tube |
| Modeling Light Duration of Illumination : | Approx. 3 sec at approx. 30 Hz (if the flash is fully charged) |
| Sensor Measuring Angle : | 20° degrees |

Guide Number Table (in feet) for Both Flash Tubes :

| ISO Film Speed | ISO 25 | ISO 50/64 | ISO 100 | ISO 200 | ISO 400 | ISO 800 | ISO 1000 | ISO 1600 |
|------------------|--------|-----------|---------|---------|---------|---------|----------|----------|
| Dual Flashtube | 18 | 25 | 36 | 51 | 72 | 102 | 115 | 144 |
| Single Flashtube | 20 | 28 | 40 | 56 | 80 | 112 | 126 | 157 |

The Guide Number (GN) when the Macrolume is set for 1/16th power output is 1/4 of the GN above.

Dimensions (W x H x D) Approx. : Macro Flash Head : 125 x 133 x 27 mm
Power Unit : 67 x 95 x 82 mm
Weight (approx.) : 376 g (without batteries)

The specifications are subject to change without notice.

Reproduction Ratio and the "Aperture/reproduction Ratio Panel"

- Determining the Reproduction Ratio

For lenses in normal position, read the number engraved on the lens focus ring. It is usually in the form of 1:n or 1/n. When using a bellows focusing attachment, refer to its instruction manual. For other lenses, follow these procedures to determine the reproduction ratio:

1. Place a ruler in the same plane as the subject, then read the subject's length as seen in the viewfinder.

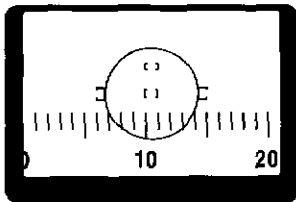

The subject's length is 21mm in this example.

2. Calculate the reproduction ratio by using this equation : $M = 36/L$

Where : M = Reproduction ratio

36 = Length of the long side of the viewfinder frame
(varies depending on camera in use)

L = Length of the subject as seen in the viewfinder

- The viewfinder frame size is 24 x 36mm for cameras having 100% frame coverage and 21 x 32mm for cameras with 90% frame coverage.
- In the above example, the viewfinder frame size is 24 x 36mm. Since the subject appears as approx. 21mm along the long side of the viewfinder frame, the reproduction ratio (M) is :

$$M = 36/21 = \text{approx. } 1.7x$$

If you measure the length of the subject by placing a ruler along the short side of the viewfinder frame, use the equation :

$$M = 24/L$$

Or if the viewfinder frame size is 21 x 32mm, the reproduction ratio (M) is $32/21 = \text{approx. } 1.5x$. Likewise, if you measure the subject by placing the ruler on the short side of the viewfinder frame, the reproduction ratio is determined by the equation $M = 21/L$.

- **Aperture to set on the Lens and Effective F-number**

Effective f-numbers of macro lenses vary and the brightness of images on the film decrease when the reproduction ratio increases. The relationship between the reproduction ratio and the effective f-number is:

$$F_e = F (1+M)$$

Where : F_e = Effective f-number (actual lens speed)

F = Aperture to set on the lens

M = Reproduction ratio

- For examples, to obtain a 1:1 (life-size) reproduction ratio at an aperture of f/8 set on the lens, $F_e = 8 (1+1) = 16$. The effective f-number is 16, which is two stops darker. Effective f-numbers are displayed on the Macrolume TTL "Aperture/reproduction ratio panel."

To obtain the correct exposure in the TTL auto flash operation proceed as follows :

- The aperture value appearing on the LCD panel or in the camera's viewfinder is the effective f-number when a lens with a built-in CPU is mounted on the camera.
- When a lens without a built-in CPU is mounted or no aperture value is displayed in the viewfinder calculate the effective f-number using the above equation after setting the aperture on the lens.

Manual Flash Mode

Use Manual Flash **M** mode, if your camera does not feature TTL auto flash operation. Flash output levels of **M** and M1/16th can be selected.

M : Flash fires at full output

M 1/16th : Flash fires at 1/4 of the full guide number.

- To obtain the correct exposure at a reproduction ratio of less than 1:10, determine the aperture using the guide number and the shooting distance.
- At a reproduction ratio of 1:10 or greater, it is difficult to obtain the correct exposure because the aperture and the effective f-number may differ.

Note

In close-up flash photography where exposures are often affected by the ambient light, it's good idea to take additional shots at various aperture setting.

(Refer to "Exposure compensation in close-up flash photography.")

1. Set the flash mode selector to **M1/16th** or **M**
2. Adjust your camera
 - Set your camera's exposure mode to Aperture-priority auto **A** or Manual **M**.
 - Set your camera's metering system to any setting.
 - The shutter speed is automatically set to the flash sync speed, depending on your camera's make and model. Or you can intentionally set the shutter speed to one slower than the flash sync speed.
3. Set the appropriate aperture on the camera or lens aperture ring.
 - At a reproduction ratio of less than 1:10, use this equation to determine the correct aperture:
$$F/\text{stop (aperture)} = \text{guide number} / \text{flash-to-subject distance (m)}$$
At a reproduction ratio of 1:10, use of this equation is not recommended as it is difficult to obtain the correct aperture.
 - With Micro-lenses mounted on the camera, refer to the "Aperture/reproduction ratio panel." For example, when shooting with an AF Micro 60mm f/2.8 lens using ISO 100 film, determine an appropriate aperture by referring to the "Aperture/reproduction ratio panel." At a 1:5 reproduction ratio, the effective f-stop for the correct exposure is f/32 at Manual (full) and f/8 at Manual (M1/16th) flash output.
 - When a lens with a built-in CPU is mounted on the camera and when you set the aperture in the camera's viewfinder or on the LCD panel, the aperture value appearing on the LCD panel or in camera's viewfinder is the effective f-number. Set this value on the camera.
 - When a lens without a built-in CPU is mounted or no aperture value is displayed in the viewfinder, calculate the effective f-number using the aperture set on the lens according to the reproduction ratio, then determine an appropriate aperture by referring to the "Aperture/reproduction ratio panel."For example:
 - At a 1:10 reproduction ratio, the effective f-number is approx. 1/3 of an f/stop smaller than the aperture set on the lens.
 - At a 1:5 reproduction ratio, the effective f-number is approx. 1/2 of an f/stop smaller than the aperture set on the lens.
 - At a 1:3 reproduction ratio, the effective f-number is approx. 2/3 to 1 f/stop smaller than the aperture set on the lens.
 - At a 1:1 reproduction ratio, the effective f-number is approx. 2 f/stops smaller than the aperture set on the lens.

Exposure Compensation in Close-up Flash Photography

In close-up macro photography, it's recommended to expose several images with varying exposures to ensure the correct exposures.

Exposure Compensation in TTL Auto Flash "TTL" mode

- Make exposure compensation on the camera to match the shooting situation. Refer to your camera's instruction manual for details on how to make exposure compensation.
- When shooting a subject containing highly reflective surfaces, add (+) compensation. When the background is very dark, or the subject is in deep shadow use less (-) compensation.
- Normally you can compensate exposure within a range of $-2EV$ to $+1EV$.
- When less (-) compensation is made, the overexposure warning indicator LED may light up in your camera. In this case, set the aperture to a smaller f-stop (larger f-number) on the lens, and then make less (-) compensation.