

# [pro]master®

## PD300 [ Digital Control Studio Flash ]

Thank you for your purchase of the ProMaster PD300 digital control studio monolight. The PD300 is designed for the photographic enthusiast who is looking for a portable, reliable, economical studio lighting solution with more advanced features. Standard features include color-temperature corrected circular flash tube (5600k), fixed reflector providing large lighting coverage and even lighting effects, continuous power level adjustment, multiple anti red-eye synch options, remote optical slave sensor, audible flash ready signal, built-in umbrella holder, and adjustable locking flash mount.

### Light Components

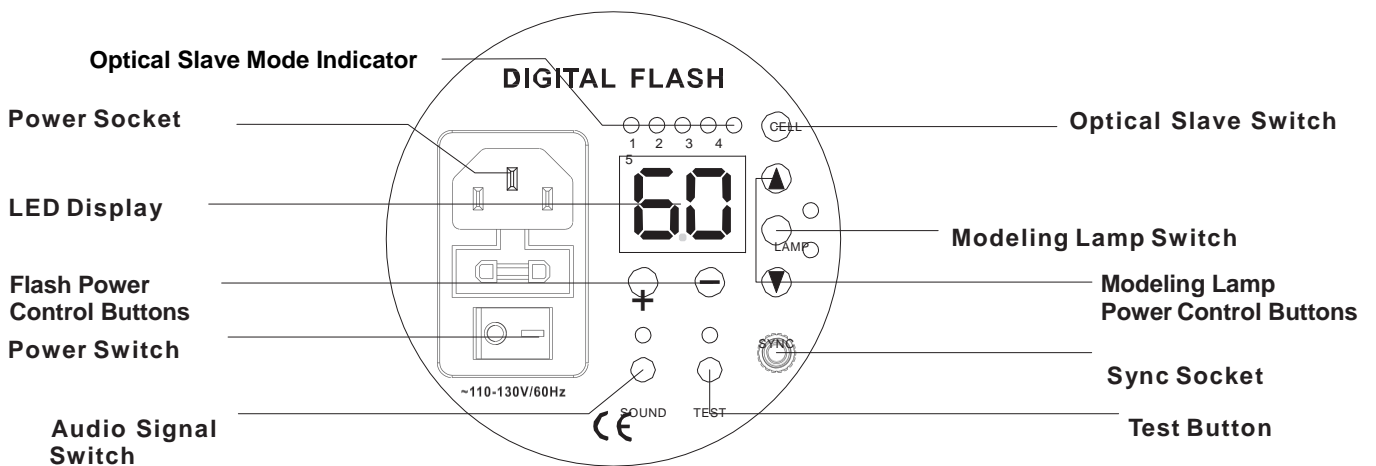
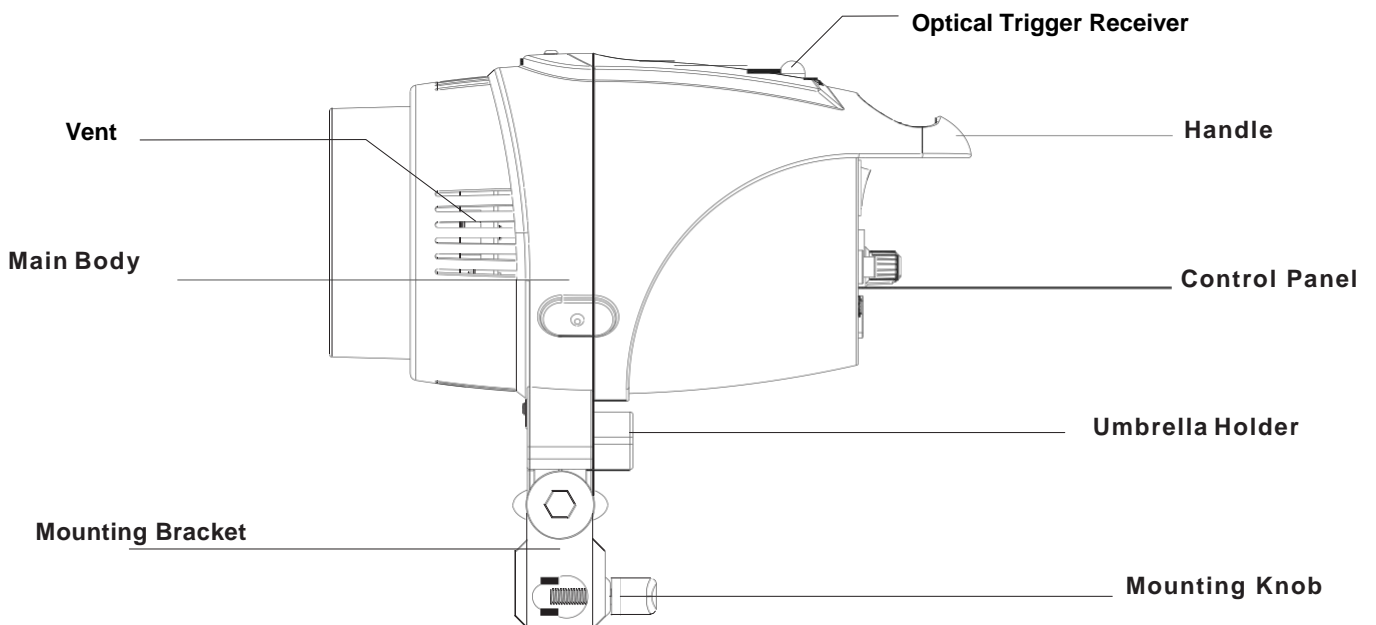

### Operation

#### LED DISPLAY

The LED DISPLAY shows the current output setting for both the flash and the modeling lamp. The settings displayed are between 2.0 and 6.0 in increments of .1.

## MODELING LAMP

The **MODELING LAMP SWITCH** is used to select the modeling lamp mode. Pressing the switch will toggle the indicator lights next to the switch to indicate the selected mode. If the top indicator lamp is on, the modeling light output will adjust in synch with the flash output and the LED display will indicate the power index. If the bottom lamp is on, the modeling lamp output is adjusted independent of the flash output index. If both lights are off, the modeling light is off.

Adjust the output of the modeling lamp by using the **MODELING LAMP POWER CONTROL BUTTONS**. The ▲ button increases the output. The ▼ reduces the output.

## AUDIO SIGNAL SWITCH

If you would like to have an audio signal to indicate that the flash is fully charged and ready to fire, press the SOUND button and the green light above it will illuminate to indicate that the audio signal is on. If you prefer to not have the audio signal, press the SOUND switch so that the green indicator lamp is off.

Note: When the audio signal is OFF, the modeling lamp will turn off when the flash discharges and will come back on when the flash is fully charged and ready to fire.

## TEST BUTTON

Press the TEST BUTTON to manually fire the flash and check its operation.

## FLASH POWER CONTROL

You can adjust the intensity of the flash using the **FLASH POWER CONTROL BUTTONS**. Use the + button to increase the flash intensity. The numbers on the LED display will increase to a maximum indicator of 6. Use the – to decrease the flash intensity. The numbers on the LED display will decrease to a minimum indicator of 1.

## OPTICAL SLAVE MODE

The flash offers 5 synchronization modes for the built-in optical slave trigger. These modes allow the flash to properly synchronize with another flash which is triggering the PD300. To select the mode, use the **OPTICAL SLAVE SWITCH**. Press the switch until the LED lamp of the **OPTICAL SLAVE MODE INDICATOR** is next to the mode you wish to use is illuminated. If all of the LED lamps are OFF, the optical slave is inactive.

### Modes:

1. **Standard Sync Mode** - When this mode is selected, the PD300 will flash instantly when another flash fires.
2. **0.5 Second Delay** – In this mode, the PD300 will ignore the first “pre-flash” and trigger with the second flash. There will be a .05 second delay from the time of the first “pre-flash” until the PD300 flashes.
3. **Trigger On Second Flash** – In this mode, the PD300 will ignore the first triggering flash and trigger instantly with the second flash from the triggering flash.
4. **Trigger On Third Flash** - In this mode, the PD300 will ignore the first and second triggering flash and trigger instantly with the third flash from the triggering flash.
5. **Trigger On Fourth Flash** - In this mode, the PD300 will ignore the first, second, and third triggering flash and trigger instantly with the fourth flash from the triggering flash.

Different cameras use a variety of flash schemes to reduce red-eye from a single pre-flash to a burst of flashes. Choosing the mode which best matches the pre-flash mode on your camera will help you to get the best results.

## Safety Precautions

1. Before using the flash, make sure that your lighting equipment is plugged into a 110 volt AC power source.
2. Do not expose your lighting equipment to sunlight, moisture, dust, dirt, rain or water.
3. Any exposure to chemical solutions, gasoline, grease, oil, paint, or detergents can result in permanent damage to your equipment.
4. Do not insert any metal objects into your lighting equipment.
5. Do not touch or handle equipment with wet hands or allow your equipment to be in contact with water.
6. Be sure to disconnect from the power supply when the light is not in use.
7. Do not attempt to repair your lighting equipment yourself.
8. Avoid rapid continuous firing of your flash. Continued rapid firing may cause excessive heat build up and potential damage to your unit.

## OVER TEMPERATURE PROTECTION

The PD300 flash features an **OVER TEMPERATURE PROTECTION CIRCUIT**. It is normal for the flash to become warm during operation. If the temperature exceeds the working limit due to excessive rapid firing, the OVER TEMPERATURE PROTECTION circuit will power off the flash to avoid damage. The red light above the power button will be off. Allow the PD300 to cool. It can be powered on again by pressing the power button.

## Specifications

**Power:** 300 watt second (joule) at full power

**Color Temperature:** 5600k ± 100k

**Guide Number:** 184' /56m @ 100 ISO

**Modeling lamp:** 50 watt / 120 volt G6.35 Bipin Halogen Lamp

**Modeling Lamp Control:** 2.0-6.0 stepless adjustment/auto adjustment/ independent adjustment/off/auto off during charging

**Power Control:** Continuous 2.0 – 6.0, 1/32 stepless adjustment

**Optical Slave:** Built-in, effective up to 35' / 10m depending on conditions; 5 synch delay options

**Recycling Time:** .2 to 2 seconds

**Over Temperature Protection:** Yes with built-in cooling fan

**Power Input:** AC110 - 130 volt, 60Hz

**Fuse:** 5 Amp – 5A 250V

**Weight:** 2 lb. 12 oz. approx.

**Size:** 9 ½" L x 4 ½" Ø x 7 ½" H (approx. With bracket collapsed)

## ONE YEAR UNCONDITIONAL GUARANTEE

If for any reason, this ProMaster product fails within ONE YEAR of the date of purchase, return this product to your ProMaster dealer and it will be exchanged for you at no charge. ProMaster products are guaranteed for ONE FULL YEAR against defects in workmanship and materials. If at any time after one year, your ProMaster product fails under normal use, we invite you to return it to ProMaster for evaluation.

**Code 9462**

**Made in China**

[www.promaster.com](http://www.promaster.com)

Fairfield, CT 06825